



Reg. No. :

--	--	--	--	--	--	--	--	--	--	--	--

Question Paper Code : X10708

B.E./B.Tech. DEGREE EXAMINATIONS, NOVEMBER/DECEMBER 2020
AND APRIL/MAY 2021

Sixth/Seventh Semester
Automobile Engineering

ME 8692 – FINITE ELEMENTS ANALYSIS

(Common to Mechanical Engineering, Production Engineering, Manufacturing
Engineering, Mechanical and Automation Engineering and Mechanical
Engineering (Sandwich))
(Regulations 2017)

Time : Three Hours

Maximum : 100 Marks

Answer ALL questions

PART – A

(10×2=20 Marks)

1. Define 'Dirichlet boundary conditions'.
2. Which weighted residual method will provide similar results as Ritz method? Why?
3. Can use a shape function that provides the sum of its derivatives zero?
4. Express the governing differential equation for a cantilever beam with appropriate boundary conditions.
5. How does a quadrilateral finite element differ from a rectangular finite element?
6. Express the shape functions for a constant strain triangular finite element.
7. What type of 2D-analysis and finite element will you prefer to analyze a water dam?
8. Distinguish a shell element from a plate element.
9. How many Gauss points should be preferred to numerically integrate a third order polynomial?
10. State the advantages of using natural coordinates in finite element methods.



PART – B

(5×13=65 Marks)

11. a) Explain the following with examples :

- i) Boundary value problems. (4)
- ii) Initial value problems (4)
- iii) Eigen value problems (5)

(OR)

b) Discuss the following weighted residual methods to find out the solutions for boundary value problems, and compare their merits.

- i) Least squares method (7)
- ii) Collocation method (6)

12. a) The furnace wall shown in Figure below consists of 30 cm of fire brick, 10 cm of insulation brick and 20 cm of red brick with thermal conductivities respectively, 0.012, 0.0014 and 0.0086 W/cm/°C. The inner and outer temperatures are 400°C and 125°C, respectively. Determine the internal temperature distribution. (13)

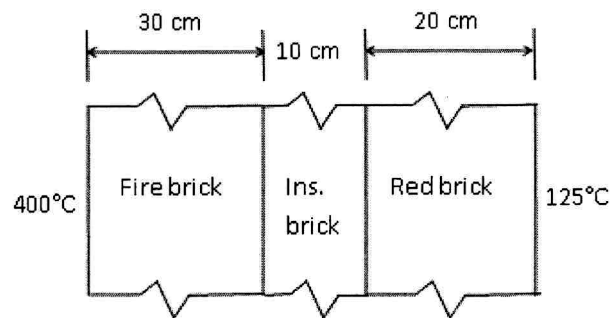

(OR)

b) Find the stresses and strains in the bar made up of steel and aluminium as shown in Figure below. The elasticity modulus of steel and aluminium are to be taken as 200 GPa and 70 GPa respectively. (13)

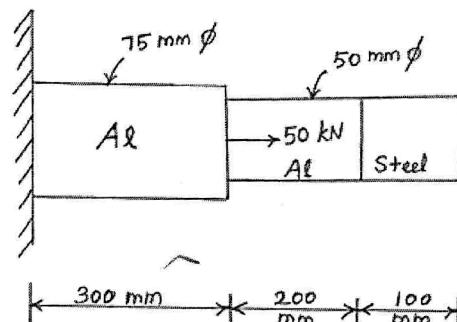



13. a) i) Brief the following : Continuity and completeness of elements. (6)
ii) Illustrate the variation of shape functions across nodes in a quadrilateral finite element. (7)

(OR)

- b) Derive the shape functions for an eight-node quadrilateral element. (13)

14. a) Calculate the strain-displacement matrix and the load vector for the CST elements 1 and 2, and the global load vector for the domain shown below. (13)

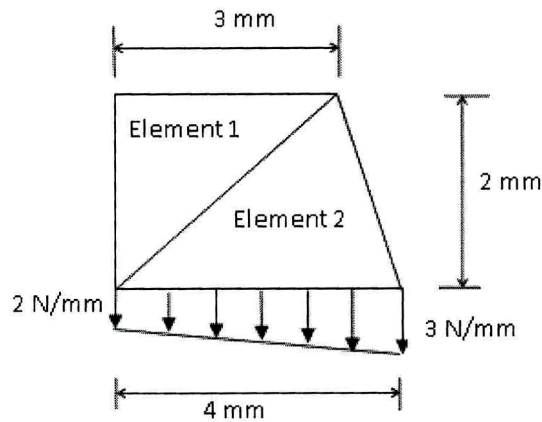

(OR)

- b) A long cylinder of outer diameter 100 mm and inner diameter 70 mm fits snugly in a hole over its full length as shown in Figure below. The cylinder is then subjected to an internal pressure of 1.8 MPa. Find the horizontal displacements of two points lying on inner radius which are vertically apart by a distance of 10 mm. (13)

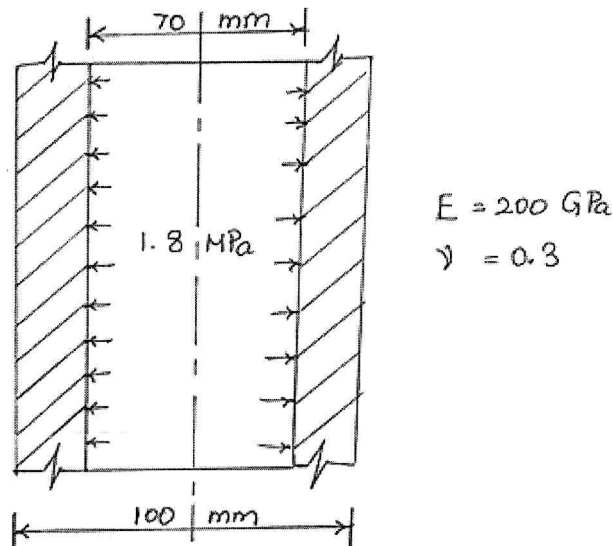



15. a) i) Explain the following : Iso-parametric, sub-parametric, super-parametric elements. (6)

ii) What are Serendipity elements ? How are they different from Lagrangian elements ? What are the advantages and drawbacks of Serendipity elements ? (7)

(OR)

b) Derive the element equation for a uniform rod experiencing free axial vibrations. (13)

PART – C

(1×15=15 Marks)

16. a) Using Galerkin method, evaluate the value of parameter C in the trial solution for the one-dimensional boundary value problem

$$\frac{d^2 y}{dx^2} + y = 4x, 0 \leq x \leq 1, y(0) = 0, y(1) = 1 \quad (15)$$

(OR)

b) Determine the deflections for the truss system shown below, where A , E , l and k respectively denote the area of cross-section, elasticity modulus, length of the truss member, and stiffness of the spring. The load P acts at the hinge joining both the truss members. (15)

